

IN-DASH STEREO INSTALLATION KIT FOR 2003-04 INFINITI G35

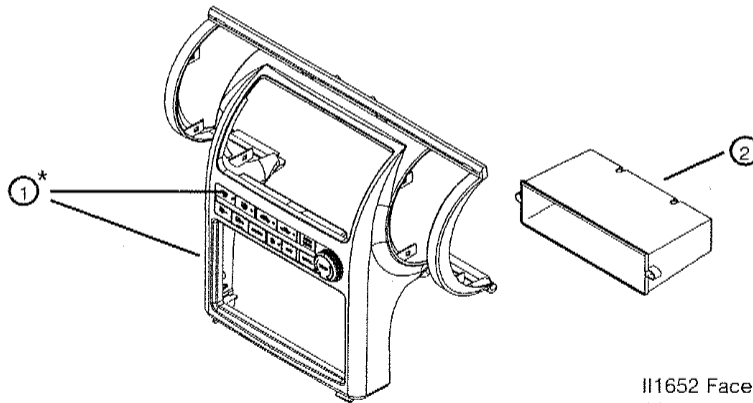

II1652 Face Panel w/
Aftermarket Climate Controls*
6552 Pocket

Tools Required:

- PRT (Panel Removal Tool)
- Screwdriver
- Picking Tool

INTRODUCTION/PRELIMINARY

This premium installation kit is for 2003-04 Infiniti G35 vehicles. Included are all the parts you need to mount your car stereo or CD player into your vehicle's dash. Refer to the individual instruction in this manual to remove your vehicle's factory radio and assemble the kit.

CAUTION: DISCONNECT YOUR VEHICLE NEGATIVE BATTERY TERMINAL BEFORE THE INSTALLATION TO HELP PREVENT ELECTRICAL DAMAGE. WE RECOMMEND THE USE OF A VOLT/OHM METER OVER A TEST LIGHT TO CHECK WIRING. A TEST LIGHT OR GROUNDED WIRE PROBE CAN CAUSE DAMAGE TO THE VEHICLE'S COMPUTER AND/OR DIAGNOSTIC SYSTEMS. AVOID ALL FACTORY AIRBAG WIRING - AIRBAGS CAN ACCIDENTALLY DEPLOY CAUSING SERIOUS INJURY OR DEATH.

NOTES

- See your vehicle's instructions for any special tools your installation might require.
- Read all instructions accompanying your car stereo for proper wiring and mounting instructions.



IMPORTANT!

DO NOT RETURN PRODUCT TO THE RETAILER

IF YOU NEED ASSISTANCE OR REPLACEMENT PARTS CALL US TOLL FREE: 1-800-621-3695 X3
HOURS: MON-FRI 8AM-5:30PM (PST) SATURDAY 8AM-2PM (PST)

LIABILITY DISCLAIMER

This instruction booklet is based on carefully documented data and research of automobile dash disassembly, wire harness/codes and information pertaining to installation of this kit (II1650B) in 2003-04 Infiniti vehicles. Scosche Industries, Inc. cannot be held responsible for discrepancies/inconsistencies that may occur due to the automobile manufacturing changes or options, or damage that may occur in the automobile during the installation of components while using this booklet.

If you have any further questions, call our toll free technical help line at:

1-800-621-3695x3

FACTORY STEREO REMOVAL

2003-04 INFINITI G35

1. With PRT, unclip shifter's boot by pushing down, then with Pick Tool, remove the clip that secures the shifter and remove shifter.
2. With flat head screwdriver, unclip shifter release cap, then push down on clip and shift vehicle to drive.
3. With PRT, unclip center consoles panel surrounding shifter, unplug and remove.
4. With PRT, unclip clock panel, unplug and remove.
5. Extract (2) Phillips Head Screws securing clock, unplug, remove and extract (1) Phillips Head Screw revealed that secures Radio bracket.
6. Extract (1) Phillips Head Screw below the hood release handle, then with PRT, unclip entire Panel, unplug and remove.
7. Extract (2) Phillips Head Screws securing center consoles left side panel where cigarette lighter is, then with PRT, unclip, unplug and remove.
8. With PRT, unclip and remove panel below glove box, (above floor panel).
9. With PRT, unclip and remove passenger's door running board. box, (above floor panel).
10. Remove passenger's rubber weather strip, (just enough to remove glove box).
11. Remove (1) plastic screw securing passenger's kick panel, then with PRT, unclip and remove.
12. Extract (6) Phillips Head Screws securing Glove Box, (2 located on the bottom and 4 located on the top inside the glove box), then with PRT, unclip glove box, unplug and remove.
13. Extract (2) Phillips Head Screws securing center consoles right side panel where 12V Power Outlet is, then with PRT, unclip, unplug and remove.
14. Extract (2) Phillips Head Screws securing Radio (located under the Radio Panel in front of the shifter).
15. With Panel Removal Tool, unclip Radio, unplug and remove.

STEREO ASSEMBLY / MOUNTING

SINGLE DIN ISO INSTALLATION INFINITI G35 2003-04

1. Retrieve (2) air-vent ducts from the OEM dash panel & place onto I11652 (locations same as OEM/ Image not shown).
2. Remove plastic trim above OEM climate control panels and place into I11652 designated location (Image not shown).
3. Connect the end of the climate controls into the radio housing and the opposite end to the factory climate control harness during final assembly.
4. Screw the pocket (B) provided onto the back of the aftermarket face panel (A).
5. Screw the aftermarket single DIN radio (C) to the OEM radio housing cage (D).
6. Slide the single DIN assembly (C+D) to the I11652 face panel assembly (A+B).
7. Connect and reassemble everything in reverse order to complete the installation.

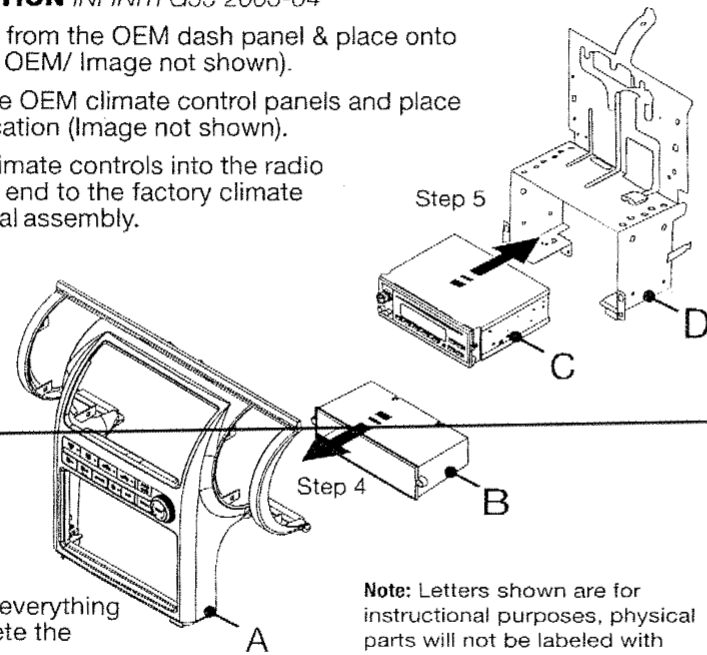

STEREO ASSEMBLY / MOUNTING

Con't.

DOUBLE DIN ISO INSTALLATION INFINITI G35 2003-04

1. Retrieve (2) air-vent ducts from the OEM dash panel & place onto I1165CHB (locations same as OEM).
2. Remove plastic trim above OEM climate control panels and place into I11652 designated location.
3. Connect the end of the climate controls into the radio housing and the opposite end to the factory climate control harness during final assembly.
4. Slide and screw the double DIN radio (B) to radio cage housing (C).
5. Slide and screw the double DIN radio cage (B+C) into the I11652 face panel (A).
6. Connect and reassemble everything in reverse order to complete the installation.

Note: Letters shown are for instructional purposes, physical parts will not be labeled with these letters

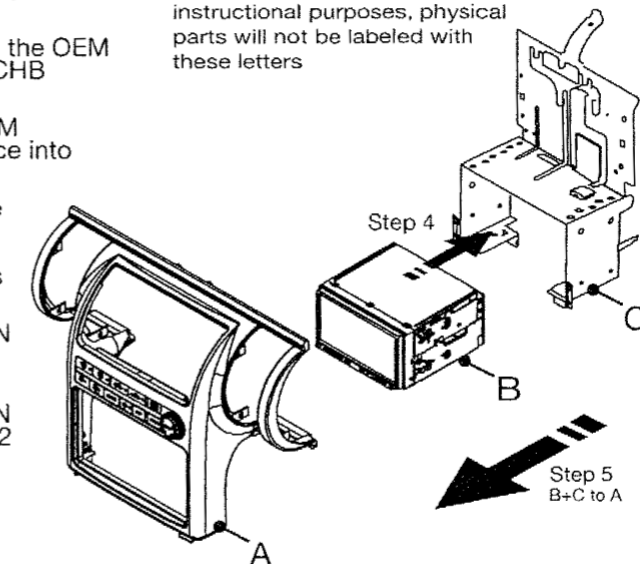

CLIMATE CONTROL

(2003-2004 Infiniti G35 Button Pack-Dual Zone)

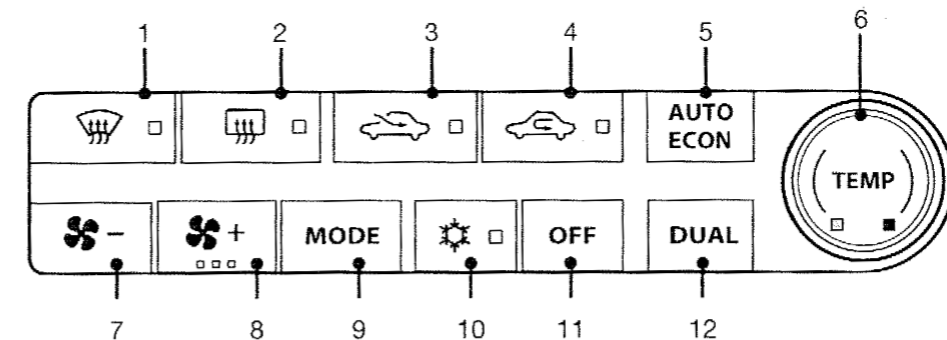

(2003-2004 Infiniti G35 Button Pack-Single Zone)

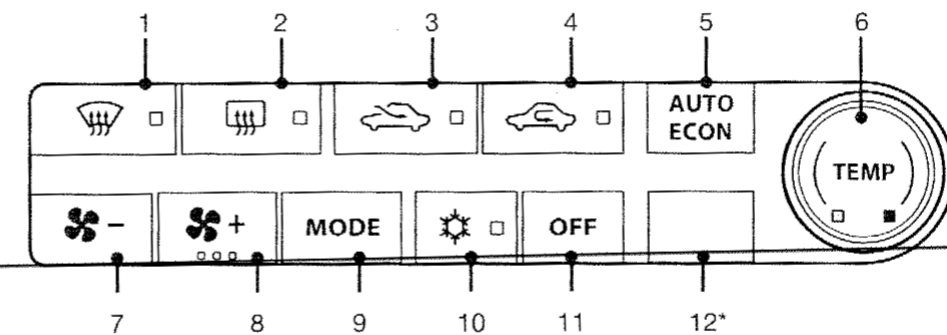



- | | |
|-------------------------------------|---|
| 1. "☀" Front defrost button | 7. "☪-" Fan speed control button |
| 2. "☐" Rear window defroster button | 8. "☪+" Fan speed control button |
| 3. "☐" Intake control button | 9. "MODE" Manual air flow control button |
| 4. "☐" Intake control button | 10. "☀" A/C button |
| 5. "AUTO/ECON" AUTO/ECON button | 11. "OFF" Off button |
| 6. TEMPERATURE control knob | 12. "DUAL" DUAL zone button *(if equipped)* |

Automatic / Economy Setting

1. " ^{AUTO}_{ECON} " button will display when it is pressed
2. Pushing the A/C button will activate the air conditioner.
3. Turn the temperature knob to set the desired temperature.
4. The AUTO/ECON mode reduces load to the engine improving fuel economy
5. AUTO/ECON button toggles from AUTO ⇌ ECON ⇌ AUTO.

Defrost / Defog

1. Push the  defrost on (Light will come on).
 2. Turn the temperature knob to set the temperature desired.
- Push the  + at max to help remove ice from outside of the windows.
 - Once the windows are clear press the auto econ button to reset the settings back to their original state.
 - When the defrosting  button is pushed the air conditioning will automatically be turned on, turning off the air circulate mode.
 - Outside air is drawn into the passenger compartment to improve the defogging performance.

Rear Window and Outside Mirror Defrost Switch



- To defog/defrost the rear window glass and outside mirrors (if equipped), push "  " once to activate and twice to deactivate. (Button indicator will be lit when active.)
- **NOTE:** This setting will remain active for 15 minutes then automatically turn off unless turned off manually prior to the 15 minutes.

Heater (A/C does not turn on)

1. " ^{AUTO}_{ECON} " button will display when it is pressed
 2. Pushing the A/C button will activate and deactivate the air conditioner.
 3. Turn the temperature knob to set the desired temperature.
- Not recommended for window fog up.

Manual Operations

FAN Speed Control

Turn the temperature knob to set the temperature desired.
 Push the  +,  - to control the speed of the fans.
 Push AUTO ECON to return to the automatic fan speed.

Fresh Air

Push the  to circulate outside air to the passenger compartments.

STEREO REPLACEMENT & STEERING WHEEL CONTROL INTERFACE FOR 2002-2007 INFINITI VEHICLES WITHOUT CAN-BUS

This LPIISR allows you to replace your factory OEM stereo while retaining factory steering wheel controls if vehicle is equipped

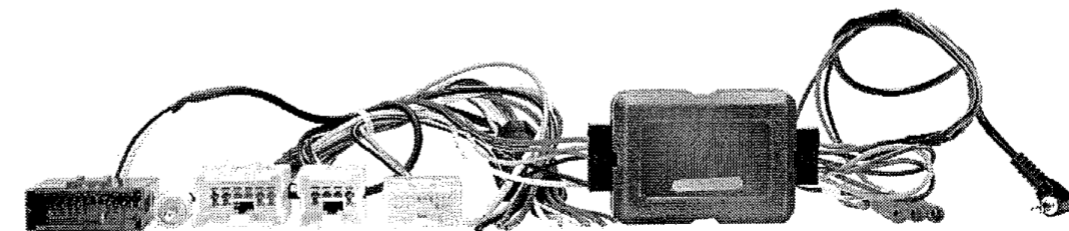

DESIGNED & ENGINEERED IN U.K
 CUSTOM MANUFACTURED IN CHINA

APPLICATION GUIDE

INFINITI:
 2003-07 G35

FEATURES

RETAINS:

- **Steering Wheel Controls** (if equipped)
- **Reverse Camera** (if equipped)
- **OEM Amplifier** (if equipped)
- **-12 Volt Acc**

LIABILITY DISCLAIMER

This LPIISR instruction manual is based on carefully documented data and research. Scosche Industries Inc. cannot be held responsible for discrepancies/inconsistencies that may occur due to the vehicle manufacturing changes or options, or damages that may occur in the vehicle during the installation of components while using this manual.

If you have any further questions, call our toll-free technical help line at: 1-800-621-3695 x3

WIRING COLOR CODES

White=	Left Front Positive (LF+)	Gray=	Right Front Positive (RF+)
White/Black=	Left Front Negative (LF-)	Gray/Black=	Right Front Negative (RF-)
Green=	Left Rear Positive (LR+)	Violet=	Right Rear Positive (RR+)
Green/Black=	Left Rear Negative (LR-)	Violet/Black=	Right Rear Negative (RR-)
Black=	Chassis Ground	Orange=	Illumination
Yellow=	+12V Constant Power		
Red=	+12V Accessory		
Blue=	+12V Power Antenna (Remote Out)		

NAVIGATION CONNECTIONS:

Yellow RCA = Reverse Camera Retention

Amplifier Retention = Install resistor park between speaker wires from radio & speaker wires from Scosche harness (Connect Male ISO to loom, Connect femal ISO to vehicle)

NOTE: The **RED** accessory output wire from the *LPII15-UB* interface is rated at 10A Max output for most aftermarket head units. **We do NOT** recommend connecting additional +12A switched accessories to this output source as that may cause damage to the *LPII15-UB* module itself. If 10A output is not sufficient, then a relay is needed. (**Relay not included**)

STEERING WHEEL WIRING CODES

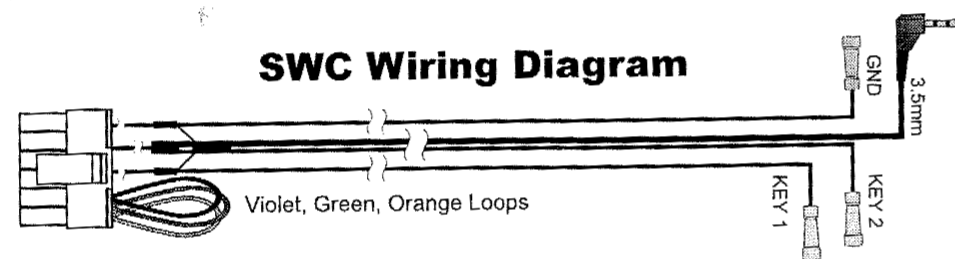

1. Prepare SWC steering wheel connector harness by using the chart below
2. Connect the harness to the interface module.
3. For Alpine, Clarion, JVC, Panasonic and Sony car stereos, connect the 3.5mm male steering plug into the steering wheel input jack at the back of the stereo.
4. For Kenwood and newer JVC stereos, connect the **BROWN** wire from the steering wheel harness to the "Remote in" wire at the back of the stereo.

STEREO BRAND	CONFIGURATION	CONNECTION TO STEREO
ALIPNE	Cut Green Loop	3.5mm
CLARION	Cut Violet Loop	3.5mm
JVC	Cut Green & Violet Loop	3.5mm or Brown (Key1)
KENWOOD	Cut Orange & Green	Brown (Key 1)
PANASONIC	Cut Orange	Brown (Key 1)
PIONEER / SONY	Do Not Cut Loops	3.5mm
OTHER BRANDS	Call Tech Support	Brown, Gray, Black

TECH SUPPORT

If you have any questions or need Technical Assistance with the installation, or the most current application please call: (800) 621-3695 Ext.3

Continued on Page 3

Continuation from page 2

SWC WIRING HARNESS

Alpine Sample 1

NOTE: Cut wire only, do NOT remove

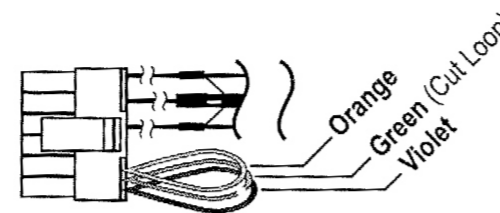

Kenwood Sample 2

NOTE: Cut wire only, do NOT remove

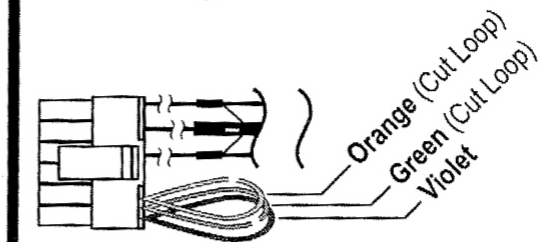

Pioneer / Sony Sample 3

NOTE: Do NOT cut or remove wires

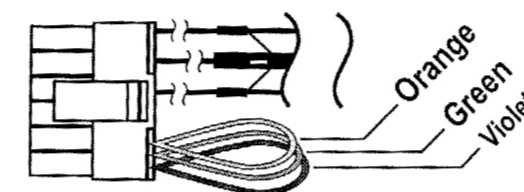

STEERING WHEEL CONTROLS

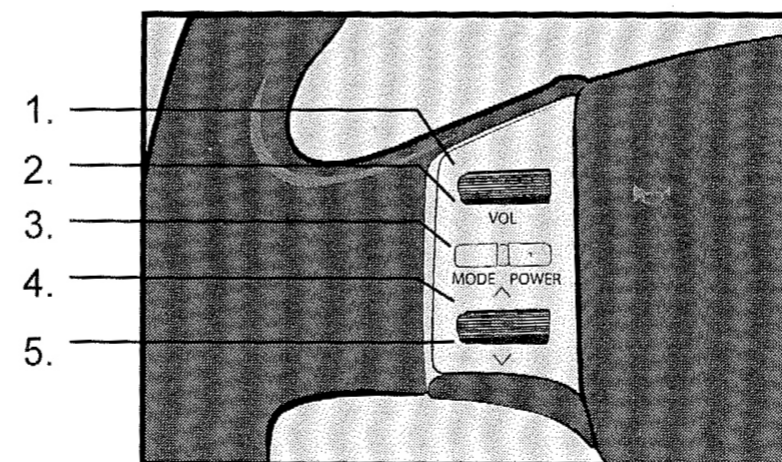

1. Volume +
2. Volume -
3. Source
4. Track +
5. Track -

Detach this page for customer use

ou have any further questions, call our toll-free technical help line at:

1-800-621-3695 x3

LPIISR WIRING DIAGRAM

AFTERMARKET RADIO

STEREO BRAND	CONFIGURATION	CONNECTION TO STEREO
ALPINE	Cut Green Loop	3.5mm
CLARION	Cut Violet Loop	3.5mm
JVC	Cut Green & Violet Loop	3.5mm or Brown (Key 1)
KENWOOD	Cut Orange & Green	Brown (Key 1)
PANASONIC	Cut Orange	Brown (Key 1)
PIONEER / SONY	Do Not Cut Loops	3.5mm
OTHER BRANDS	Call Tech Support	Brown, Gray, Black

NOTE:

If factory amplified add Resistor Pack in-between Radio & Harness Speaker Wires

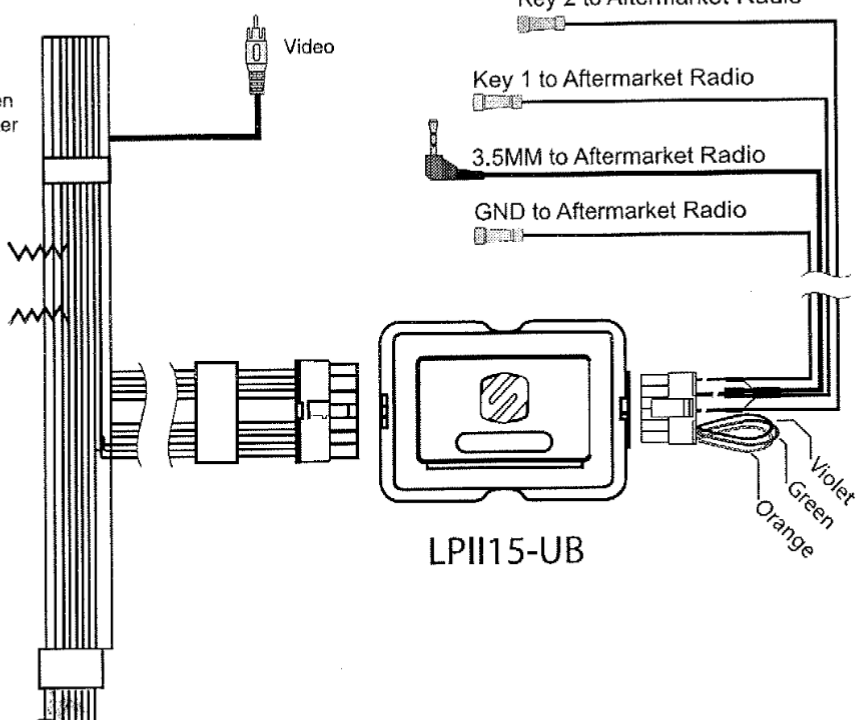
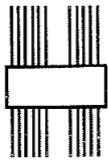

LPII15-UB

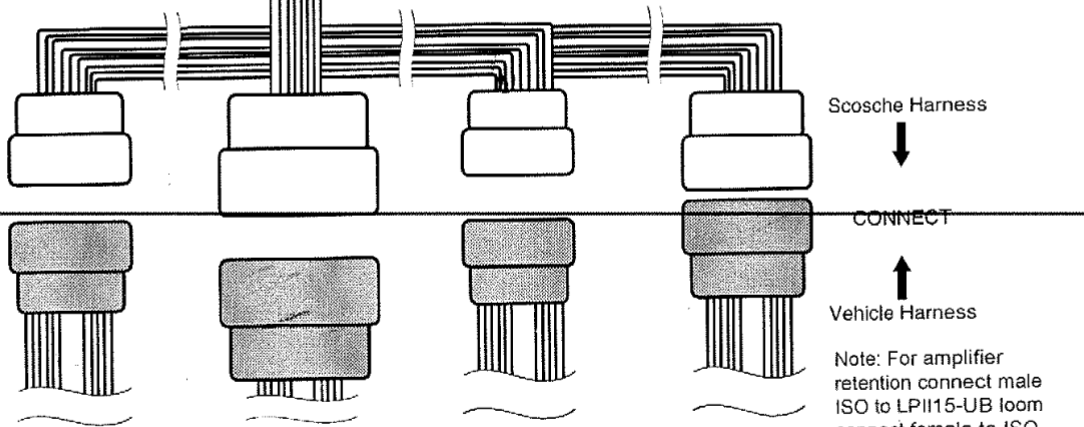

Scosche Harness

CONNECT

Vehicle Harness

Note: For amplifier retention connect male ISO to LPII15-UB loom connect female to ISO vehicle