

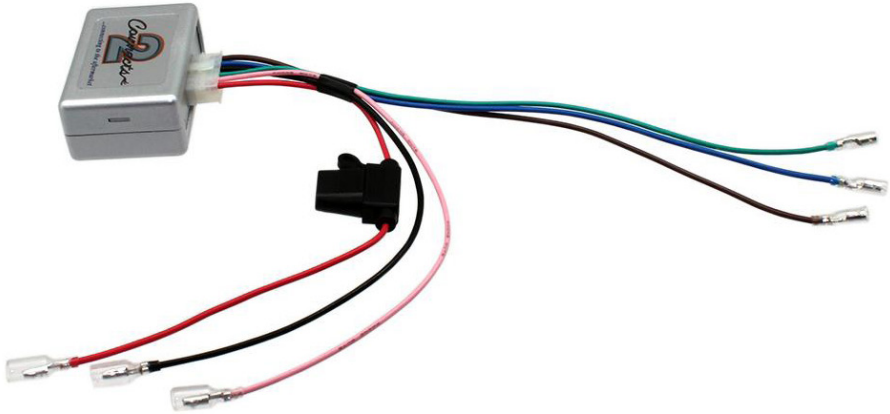

CT54-04

Universal 24V-12V Voltage Dropper



PRODUCT FEATURES

The CT54-04 is a plug and play voltage dropper that is a perfect for those looking to install any aftermarket stereo/accessories into a vehicle where the voltage output is higher than standard. The CT54-04 regulates a constant feed of 10A and can withstand high inputs of voltage commonly used within the commercial industry.

PRIOR TO INSTALLATION

Read the manual prior to installation. Technical knowledge is necessary for installation. Please ensure you use the correct tools to avoid damage to the vehicle or product.

Connects2 can not be held responsible for the installation of this product.

DISCLAIMER

The information provided in this document is subject to change without notice due to manufacturer changes and/or improvements to the product/s. This instruction manual is based on documented data and research. The manufacturer of this product cannot be held responsible for any changes made to the vehicle by the manufacturer or damages that may occur through the installation of this product in accordance with the steps outlined herein.

PRODUCT SPECIFICATIONS

	Min	Max
Power Input Voltage	18V	30V
Output Voltage	13V (+/- 0.1V)	
Remote Input on Voltage	18V	30V
Remote Output on Voltage	13V (+/- 0.1V)	
Output Current - Continuous	10A	
Output Current - Maximum	12A	
Standby Current	<17mA	
Efficiency	90%	95%
Operating Temperature	-40°C ~ +85°C	

The CT54-04 also features protection against input polarity inversion, under/over voltage and overloading/heating.

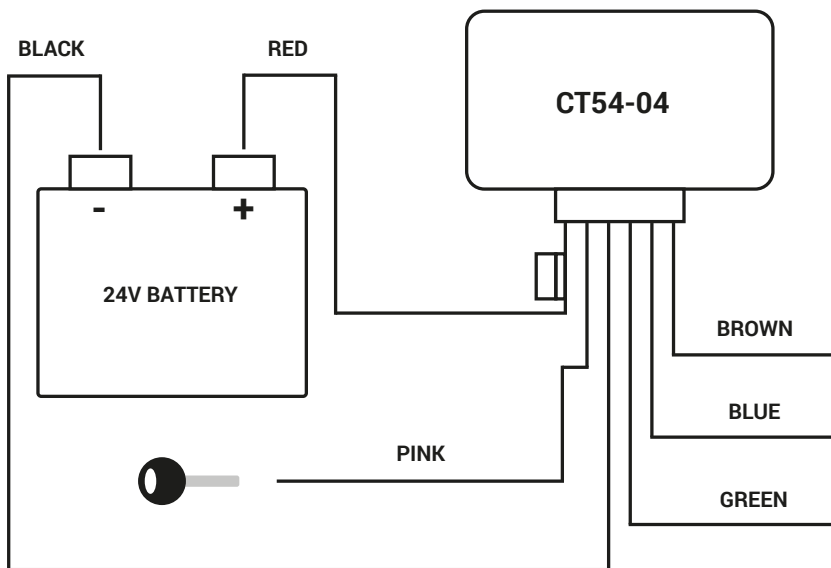

Wiring on CT54-04 harness:

- BLACK - Connect to source of input Ground (24V)
- RED - Connect to source of input Battery Live (24V)
- PINK - Connect to source of input Ignition (24V)
- BROWN - Connect to source of output Permanent (12V)
- BLUE - Connect to source of output Ground (12V)
- GREEN - Connect to source of output ACC (12V)

Need help? Visit support.connects2.com/tickets/technical

CT54-04_IG_v1